

Steele School for Early Learning
5030 Carr Street, Arvada Colorado 80002
Phone:303-431-5653
Fax 303-431-0636

Parent Policy Handbook

Greetings
About Our Staff
Admission Procedures
Admission Policy Statement
Authorization For Medication Authorization Forms
Authorization For Topical Medication Form
Absences
Accident-illness
Adjustment, Transition, And Probation
Allergies
Birthdays
Childcare School Hours/ Late Pick Up
Childcare Statements
Classroom Visitors
Concerns
Conduct - Safety / Discipline
Curriculum
Diapers And Supplies
Dismissal
Dress Code For Preschoolers
Emergency Procedure
Drills And Evacuations
Fundraising
General Policies
Children With Special Needs
Holidays
Hygiene
Inclement Weather Policy/ Delayed Start
Infant And Toddler Policies
Delayed School/Childcare Opening
Labeling Of Clothing - Lost And Found
Meals
Missing Or Lost Person
Parent Involvement
Parent-teacher Communication
Parent-teacher Conferences
Pictures
Programs, Goals, Philosophy
Propagandizing And Solicitation
Release Of Children
Reporting Suspected Child Abuse
Rest Time
School Campus Security
School Visitors
Sick Child Policy
Sign In And Out Sheets
Smoke-free Environment
Sunscreen Policy
Infant & Toddler Policies
Tuition Policy
Tuition/Bank Charge
Tuition/Family Rates
Tuition/Past Due Accounts
Toilet Training
Video And Television Viewing Policy
Withdrawals
*Highly Infectious Illness Preparedness Plan

GREETINGS from Steele School for Early Learning. We are state licensed and serve all members of the community.

The childcare is licensed for children 6 weeks – 12 years of age. Our childcare is adapted to a child's world so he/she can develop in all phases of early childhood in a protective and pleasant environment. The following information is to assist you in planning for a successful school year by listing our guidelines and regulations, and by providing some general information. If you have further questions, please feel free to discuss them with the administrative office at Steele School for Early Learning. We have an open door policy and are happy to hear your questions or concerns at any time.

The mission of Steele School for Early Learning is to provide children with a safe, loving, respectful, quality environment where children can learn and grow. To provide parents with a safe, worry free, nurturing environment that is respectful of each family's values.

ABOUT OUR STAFF

All staff employed at Steele School for Early Learning have undergone a criminal background check through the Colorado Bureau of Investigation, FBI and Dept of Human Services on all staff members.

The teachers and staff are all mature adults who understand the requirements to care for children in Infants through Pre-Kindergarten. All are trained in early childhood education and development, and are selected because of their knowledge, love, sympathetic understanding, and ability to teach young children.

ADMISSION POLICY PROCEDURES

Call or email the school office to arrange for a personal tour of the facility. The registration fee is equal to one week of tuition set forth on the rate sheet for the age group your child falls in upon enrollment. Once the registration fee and paperwork are completed this reserves your spot for your intended start date. This fee is non-refundable and does not apply toward your tuition. If no room is available you will have the option to be placed on the waiting list. You will be notified as soon as space becomes available.

The following forms must be completed and returned to the school office before your child's enrollment and registration becomes official. All forms must be updated every January regardless of start date. Please see the Student health records and immunization sections for more information.

- REGISTRATION/EMERGENCY FORM: (Annual)
- CHILD PICK UP INFORMATION
- EMERGENCY INFORMATION AND AUTHORIZATION.
- HEALTH HISTORY.
- CONSENT AND RELEASE.
- TOPICAL OINTMENT ADMINISTRATION
- TUITION AGREEMENT
- ADMISSIONS POLICY STATEMENT

IN ACCORDANCE WITH TITLE VI OF THE CIVIL RIGHTS ACT OF 1964, it is our policy to admit and to treat all children without regard to race, color or national origin. The same requirements for admissions are applied to all students. Children are assigned within the school without regard to race, color, or national origin. There is no distinction in eligibility for, or in the manner of providing to any child, the services provided by or through the auspices of Steele School. All persons and organizations having occasion either to refer children for admissions or to recommend Steele School for Early Learning are advised to do so without regard to the child's race, color or national origin. If you have any questions concerning compliance, talk first with the Director, If you have further concerns, you may contact the Executive Director of Colorado's Department of Human Services, 1575 Sherman Street, Denver, Colorado 80203 or the Regional Director of the Office of Civil Rights, Department of Health, Education and Welfare, 1961 Stout Street, Federal Office Building, Room 9017 Denver, Colorado 80294.

AUTHORIZATION FOR MEDICATION AUTHORIZATION FORMS: In accordance with regulation 7.702.62C, "Prescription and non-prescription (over-the-counter) medications can be administered only with the written order of a person with prescriptive authority and with parental consent." **If Your Child Requires Medication While at Child Care or School:** All prescription and nonprescription medication given in child care or school settings require a written authorization from your healthcare provider, as well as parent written consent. This is a child care licensing requirement. The medication authorization forms are available from the director or can be sent via email (forms in the near future will be available on our website). The instructions from your health care provider must include information regarding the medication, reason for the medication, the specific time of administration and the length of time the medication needs to be given. All medications must be brought in the original labeled container. Note: Medication prepared in a bottle or "cup" may not be left with program staff. Vitamins are considered like any other medication, please do not leave them with your child. Program staff involved in medication administration receive special training and are supervised by a nurse consultant. Program staff is not authorized to determine when an "as needed" medication is to be given. Specific instructions are necessary. For children with chronic health conditions, this can be determined in collaboration with the consulting registered nurse. Any expired medication that is not picked up within one week from the director's office will be disposed of per FDA regulations.

AUTHORIZATION FOR TOPICAL MEDICATION FORM

This form gives Steele school permission to apply topical ointments that are being used as a preventative. Examples are diaper cream, lotion, and sunscreen. Note: diaper cream may only be applied if the skin is not broken.

ABSENCES

We assume that your child is going to be here every day that he is scheduled to attend. If your child is going to be absent, please call or email as early as possible that morning so that the teacher can plan accordingly. If your child has contacted a communicable disease, please contact the school immediately so that we can let our other parents know. Your child's name and classroom will not be released.

ACCIDENT- ILLNESS

If your child becomes ill. The Main Office staff will notify the parent(s) or guardian(s) as soon as possible.

It is school policy that parents be notified if the child is running a temperature. The temperature will be taken at least 3 times with 5 minute intervals in between. If the temperature is 100.4 degrees or more (100 for infants) you will be asked to pick your child within half an hour, with the recommendation that you contact a physician. Steele School policy also requires the child to be fever free for 24 hours (without fever reducer) before returning to care. They must also be able to eat, drink, and participate in all school activities. Steele School reserves the right to extend exclusion periods as needed based on many factors.

Parents will be informed of any accident or injury by way of an “Accident/Illness Report” which will be given to you to be read and signed before the child leaves for the day. You will be notified by phone if the injury might require further attention or a doctor visit.

In case of an emergency, if parents cannot be reached, we will call your emergency contacts indicated on your Emergency Form or emergency services at Steele School’s discretion.

During an outbreak, we will follow our Highly Infectious Illness Preparedness Plan, and all exclusion periods outlined in it. See our Highly Infectious Illness Preparedness Plan below.

ADJUSTMENT, TRANSITION, AND PROBATION

At any school there is a time of social adjustment and transition for the child AND the parents. However, if at the end of this time period we feel that your child cannot adjust, shows aggression toward teachers and other students this includes biting, hitting, spitting or throwing things. We may ask that you find another childcare center which will better meet your child’s needs.

We want you to know that we will help you and your child in any way that we can. These next weeks and months will be filled with lots of love and compassion for you and your child.

We urge all of our parents to communicate with the administration and teachers about any questions or concerns. You may request a meeting at any time..

We want your child to become a strong individual within their families, neighborhood, and at our school. We want your child to be happy and to grow physically and mentally, while they are with us. We’re looking forward to a bright and exciting future with you!

ALLERGIES

Steele School is a nut & strawberry free facility. If your child has allergies to certain foods (i.e. milk, peanut butter, cheese, etc.) we are, by law, required to have a signed note from your physician or health care provider that your child is not allowed to receive these foods. An allergy plan must also be provided. The physician may suggest substitutions that your child may have during his/her meal (parents are to provide any food substitutions). Please

also notify us if your child has food preference- ie. vegan, vegetarian, ect. Each classroom is provided an allergy list to be kept in a confidential area, so that all staff are aware.

Due to severe **nut and strawberry** allergies, no nut or strawberry products may be brought for any party treats, lunches, or snacks.

BIRTHDAYS

Birthdays are very special occasions. You are welcome to send a nutritious treat for the class. This must be store bought and brought in the original packaging. Please no sweets. Please make arrangements with the classroom teacher. Treats will be given out during P.M. snack time and we will do our best to make it a special day for your child. Due to severe nut allergies, we ask that no nut products or foods that are manufactured in a facility that contains nuts be brought for any party treats.

If your child wishes to host a birthday party and invitations need to be sent, give the invitations to your child's teacher, and the teacher will make sure they get sent home. It is suggested that you invite the entire class of girls/boys to avoid hurt feelings.

CHILDCARE SCHOOL HOURS

The childcare center is in session Monday through Friday. Our doors open promptly at 7:30 a.m. and close promptly at 5:30 p.m., until April 2021. The closing staff members will stay with all children until they are picked up. Drop off may not be later than 10:30 a.m., unless the child has a doctor's appointment. An email or a phone call must be made ahead of time to notify the admin that your child has an appointment. Late drop off due to doctor appointment may be no later than 12 p.m. and your child must have had lunch. Planned closure dates are posted in June for the upcoming school year.

LATE PICK UP

In the event of a child left after 5:30 parents and/or emergency contacts will be notified by phone starting at 5:30 p.m. If the parent cannot be reached, we will make every effort to call all the numbers listed on your emergency form. If no one can be reached after 1 hour we are required to contact the Department of Human Services.

Parents must pick up and be out of the building by 5:30. pm, please arrive no later than 5:20 to ensure you have time to pick up your child before 5:30 p.m. Parents will be charged a fee of \$3.00 per minute per child, starting exactly at 5:31 pm, this fee is payable at the time of pick up or the next scheduled day of attendance in cash. Exact change only. Any fees not paid within 2 days of attendance will be charged an additional fee of \$5 per day per child. Please place payment in the tuition box marked with your child's name and date that the payment is for. We would ask that you plan to always be here on time as it does cause your child stress and anxiety when parents are late. Frequent violations of this policy will result in disenrollment.

In the event of an emergency, please call Steele School for Early Learning at 303-431-5653. If not available please call 303-809-0158.

CHILDCARE STATEMENTS

Childcare statements are available by February of next calendar year. Please contact the Owner if you would like to have a child care statement provided. Also notify us if your contact information has changed. You must allow at least 1 month for the statement to be processed and be current on all fees and tuition.

If you need monthly statements for dependent care reimbursement you will need to provide the correct forms and/or the specific information and formatting needed. You must allow at least two weeks for these forms to be completed. Please send information needed to the owner.

CLASSROOM VISITORS

There are several things that must be considered before a request to visit a classroom can be granted. Only parents of a child will be allowed to spend time in the classroom observing. In the case of extended family, each parent must write a note approving the visit to the classroom by anyone other than the birth parents. Privacy issues must be considered when allowing visitors to the classroom. If the visit is for things like speech therapy or OT these must be approved by the Director or Owner first so we can coordinate. The visit must be coordinated with the director, and the classroom teacher. It should take place at a time when it will cause the least amount of confusion to the classroom dynamics. Visitors must sign into the visitor log, and be in proper dress.

CONCERNS

If you have a concern/complaint you should first address the director or owner. If your concern is not addressed to your satisfaction, you may contact The Division of Childcare, The Colorado Department of Human Services, 1575 Sherman Street, Denver, Colorado 80203-1714.

CONDUCT-SAFETY/DISCIPLINE

We believe that teaching children appropriate behavior is an important part of their education; we will use positive behavior support to teach and encourage children positive behavior.

Children will receive guidance regarding the proper behavior and instruction as to how to handle all emotions to include, but not limited to, anger, frustration and peer interactions.

Children will be made aware of the classroom rules each day and rules will be posted in each classroom. We believe that all children desire to make good choices and be accepted by their peers. We feel a strong responsibility to give the children the tools they need to have positive social interaction with their peers, family and the greater community.

In the event that a child does not respond to positive guidance techniques, we will request a meeting with the parents, at that time the child may be placed on a behavior support plan devised by the Director, Teacher and Parents.

If it is later decided that the child is not meeting the milestones set in the plan within a given timeline, the parents will be contacted for another meeting. If your child is causing harm to staff or other students parents will be asked to pick the child up. Return to school will be at admin discretion. Steele School for Early Learning reserves the right to deny further enrollment to any child unable to comply with the guidance offered here. This would be a last resort.

Constructive methods for behavior are used for maintaining group control and handling individual behavior. Corporal punishment and other humiliating or frightening techniques are never used.

It is understood that the services of the school are engaged by mutual consent: and that, either I or the school reserves the right to terminate any or all services at any time.

CURRICULUM

Steele School for Early Learning provides an enriching, academic based curriculum, based on age appropriate, child centered activities, hands on activities. Teachers focus their lesson plans around the interests of the children to help keep them engaged. Children are provided with large blocks of time to explore and interact with other children in the group. We will provide children with outdoor time each day,(weather permitting) so we would ask that you provide your child with clothing appropriate for the weather.

DIAPER AND SUPPLIES

Parents will be given a list of items to bring to school. Be sure you send an ample supply of diapers. Your child's diapers will never be used for other children. Disposable diapers are preferred, however if cloth diapers are used, each soiled diaper will be sent home in a wet bag that the parent is required to supply. (According to State regulations, we are not permitted to rinse soiled clothing.) A clean cover is required for every change.

When supplies run low, you will be asked to bring these. If you do not provide them, after 2 attempts, you will be charged \$2.00 per diaper and \$2.00 per day for wipes.

DISMISSAL

The school reserves the right to dismiss/disenroll any child whose tuition payments are more than two weeks in arrears, without verbal or written communication from the parent to the office.

DRESS CODE FOR PRESCHOOLERS

Children Toddler through Preschool may wear any type of clothing that is easy for them to remove in the event of toileting or diapering. We request that they wear sturdy shoes or sandals with backings. We encourage the child to wear socks with shoes or sandals. For safety reasons, no "flip-flop" type, or backless shoes will be allowed ("Crocs" are discouraged). We ask that you label the children's extra clothing with his/her name in permanent marker. All girls must wear shorts under their dresses,

Please note: Children do get messy, so please keep in mind that children should be dressed for a busy, maybe messy day.

EMERGENCY PROCEDURE

In the event of an illness or accident needing medical attention, we will follow the parents instructions as stated on the Emergency Form. Steele School for Early Learning will always try to reach the parents, but in the event we are unable to contact you, it is the responsibility of the family to accept the expense for emergency medical treatment.

DRILLS AND EVACUATIONS

During fire drills or an actual emergency, the approved plan of exit will be used with teacher and staff supervision. Monthly drills will be held to familiarize the children with proper procedures set forth by the Fire Department.

Each quarter we will also practice other drills such as lock-in, lock-down, and tornado.

In the event of a fire or tornado or other unforeseen disaster, all children and school personnel will either be evacuated from the building or gathered in the safest location for the situation.

Evacuation Sites

Neighborhood (Evacuate building)- Faith Christian 4890 Carr St. Arvada, CO 80002
Secondary Neighborhood (Evacuate building)- Head start 5150 Allison St, Arvada, CO 80002
Out-of-Neighborhood (Evacuate area)- Mountain Phoenix 4725 Miller St. Wheat Ridge, Co 80033

FUNDRAISING

Tuition and fees provide only a portion of the total operating costs needed to provide quality education for your child. Private schools receive no outside funding and must make up for shortfalls in tuition and revenue.

Therefore, parents of private school students are asked to take an active part in one or more areas such as fundraising, volunteering, donations, etc.

Steele School for Early Learning strives to keep tuition costs at a minimum and can only continue to do so with parent cooperation and participation.

GENERAL POLICIES

1. Parents are to provide their own transportation for each child, both to and from the childcare center. Childcare personnel WILL NOT release the child to anyone other than the child's own parent/guardian or other adult authorized by the parent. If specific individuals are not allowed to pick up a child we must have their name on file and/or a legal paperwork order. Childcare staff may not take children home.
2. PLEASE DO NOT allow your child to bring food, gum, candy or toys. (unless it is for Show and Tell) to school at any time.
3. It is your responsibility to read the newsletters that are sent via email and notices sent home with your child. This contains important information regarding special activities, picture days, school closures, supplies needed, etc.
4. Your child is always welcome to bring a favorite storybook or other educational material to share with the class. Please ask your child's teacher first for the best time.
5. Any change of home address, phone numbers, or place of employment, should be reported to the school office IMMEDIATELY. Updated forms will be sent out annually.

6. In order to facilitate a child's independence, care should be taken to see that clothes fit, have large buttons and buttonholes, or a zipper down to front, Shoes should have laces with tips and no knots.

7. Children often take puzzle parts, little cars, and other items home in their pockets entirely by accident. They slip them into their pockets to have them 'handy' and then forget to put them back. We would appreciate parents returning these items to the school.

8. For Toddlers and Infants you will receive a daily report informing you of how your child's day went: nap times, how well he/she ate highlights of the day, etc.

9. If you have outside interests to supplement your income, the childcare center MAY NOT be used as a source of solicitation. (asked to babysit, buy from students ect..)

10. Discipline and guidance will be consistent and based on an understanding of the individual needs and developments of the child and will be directed toward teaching the child acceptable behavior. Children will not be subjected to harsh and cruel treatment, humiliation, abusive language, or punishment associated with food, napping, or toilet training. Our staff will employ distraction, redirection, verbalization of feelings, teaching by example, and ample praise for appropriate behavior. The above healthy outlets for emotion teach skillful adaptation to interaction with others and teach the child acceptable outlets for negative feelings. Our staff will react positively in a fair, clear, and consistent manner in a happy relaxed classroom atmosphere. Parents will be notified and a meeting may be necessary with administration to ensure that children who exhibit certain behaviors that are considered harmful to the class, themselves, or the staff are addressed.

11. All children are required to pay for all days in the week whether in attendance or not. Tuition is due the first day they attend each week or due the 1st of the month for monthly payments.. We ask that you indicate the dates you are paying for on your check or in the notes/memo section for online payments.

12. TUITION IS ALWAYS DUE IN ADVANCE. We accept payments in CASH, CHECKS, MONEY ORDERS, and VISA Payment may be made online at www.arvadapreschool.com. Look for the make a payment tab and follow instructions. In the notes section you must include the child/ren name(s) and week or month paying for.

CHILDREN WITH SPECIAL NEEDS- As stated in A7411.1#2: Rules and regulations set forth by the Department of Social Services, Steele School for Early Learning does accept children with special needs if we feel we can be of help to them. Children with special needs will be accepted on an individual basis.

HOLIDAYS

The school is closed for all federally accepted holidays. We also close for teacher training days. (These are paid tuition days) Please refer to our school calendar for complete listing. Check School Calendar and weekly newsletters for Holidays and school closing.

There will be no adjustment in fees for any of these holidays.

HYGIENE

Steele School for Early Learning will include provision for personal hygiene, such as washing hands upon arrival, new classroom, after playing outside, before meals and after using the toilet. Disposable towels will be used. If a child has a “bathroom accident”, wet or soiled clothing will be changed promptly. We will dress your child in the extra set of clothing you provide. State regulations specify that we are not allowed to dump and/or rinse soiled clothing. They require that soiled (poopy) clothing be sent home in a zip-lock, wet bag, or grocery bag with all contents .

INCLEMENT WEATHER POLICY

SCHOOL CLOSURE DUE TO WEATHER

Steele School for Early Learning will follow the Jefferson County Public School system weather closure schedule. As part of that we will observe the same extreme weather closure days as the county. In case of circumstances that would necessitate the closing of school, such as blizzard, snow storm, tornado, or natural disaster, parents should listen to or visit: Channel 9 news or <https://www.jeffcopublicschools.org>. Please listen/visit these stations or call the school. In the event school is to be dismissed before the regular closing time, these same stations will make announcements, or individual calls may be made. In addition to the news stations, an email will be sent, a post to our facebook page, and our voice mailbox will be changed to ensure proper communication. In the event of inclement weather and Jeffco is not in session, the call will be made by the owner. It will be posted and/or sent out by 5:30/6:00 am.

DELAYED SCHOOL/CHILDCARE OPENING

If Jeffco schools call for a delayed start we will open at 9:30 a.m. This information will be sent via email, posted to our facebook page, and our voice mailbox will be changed to ensure proper communication. On days there is a delayed start the cut off time for arrival will be extended to 11am

The tuition will remain the same and no refunds or credits will be given.

Children will not be taken outside to play during inclement weather (if it is snowing, raining, lightning, black clouds, high winds, or excessively hot/cold weather, etc.). Children will be offered a drink of water whenever needed as well as following outside play. On excessively hot weather days the children will be kept inside the building or in a shaded area. Labeled sippy cups or water bottles should be sent to school, and must be taken home everyday. The childcare teacher will take these outside whenever the children go out to the playground.

INFANT & TODDLER POLICIES

General Information

Every day you will receive a daily report informing you of how your child’s day went: nap times, how well he/she ate, his/her diaper schedule, etc.

Infant bottles must be brought in pre-made, labeled with your child's name, date, and contents. It is recommended that you leave one clean bottle and formula in case of emergency. If sending breast milk, please label each bottle as breastmilk, with first and last name, date and red band (band provided by us). You may bring one frozen bag to be used as an extra. This must go home at the end of the day.

Please label all bottles and food with first and last names and contents. Everything must go home at the end of the day.

Bottles, Sippy Cups and Beverages;

Infants will not be allowed to move to the next classroom, until they are completely bottle free.

Infant/Toddlers must always be sitting when drinking from a sippy cup. Water or milk only.

Mealtimes and Snacks;

Parents provide all food for infants. Infants will wear a bib at mealtimes. After they eat, their faces and hands will be washed with soapy water. We will wash bibs and washcloths daily. The staff member will supervise them when they are eating, and if necessary, feed them.

Due to allergies with infants, all food that is brought to school must have been tried at home at least three times.

If a child has specific allergies or special dietary needs, please notify the director and supplement as needed.

Miscellaneous;

If car seats are brought to school, please place them in the designated area in the classroom/outside the classroom. Children are never placed in a car seat for disciplinary reasons or at any other time. Children also may not be left sleeping in car seats. Staff are not allowed to remove children from car seats or buckle them in.

An evacuation crib will be used for transporting infants for fire drills. Toddler wagons will be used to transport toddlers during evacuation drills.

LABELING OF CLOTHING – LOST AND FOUND

Your child's clothing, especially jackets, coats, boots, etc. should be permanently marked. Items that have been "lost-found" will be accumulated on a weekly basis and brought either to the school office or the "lost and found barrel". You or your child may check the barrel at any time. At the end of the year, the items that we have collected and that have not been claimed will be given to a charitable organization.

MEALS

A nourishing snack is provided during the day. Parents will pack a nutritious lunch, do not send sweets, strawberries, or nuts. Sufficient time will be available for snacks to be unhurried. Infants will provide all food and formula used here at school. Infant 2 will be offered snacks.

If a child forgets a lunch, the school will provide one that meets all the USDA requirements. The first time one is forgotten there will be no charge, thereafter it will be a \$4 charge each time. This is due the next day.

MISSING OR LOST PERSON

Should a child be missing, staff will search the building and ground completely. If the child is still not found, the police and parent/guardian will be notified while staff continues searching the immediate surrounding area.

PARENT INVOLVEMENT

Parent involvement is very important. You will receive monthly newsletters from your child's teacher indicating what we have done, what we are doing, and what is ahead. We need parents to help with school functions with school functions, ground maintenance, and help with programs. We would love to involve you!!!

PARENT-TEACHER COMMUNICATION

Newsletters will be sent home or emailed outlining what they will be doing. Please be sure to read and note anything that affects you or your child, and to keep informed of new school policies as well as other important information. We have provided each child with a "mailbox/cubby" to serve as a place to put all their papers, reports, receipts, etc. Please check your child's mailbox each morning and evening that you come.

PARENT-TEACHER CONFERENCES

You may call the school office and request a conference with the administration, childcare director, and/or teacher anytime you wish to discuss a concern, questions, or problems regarding your child. Pre-K students will have conferences in October and April.

PICTURES

Pictures of your child may be used in any Steele School publication including but not limited to Steele School brochures, newsletters and websites. This is part of the enrollment packet. If you wish for your child picture to not be taken or used, mark on consent and release form and notify admin. Because of this we ask that you do not take pictures or videos of other children.

PROGRAMS, GOALS, PHILOSOPHY

Children grow in many ways, some of which may be summarized by the following terms: physical, cognitive, emotional, and social, Programs committed to excellence in design and practice, will be developed to enhance and nurture growth in the many areas in a child's development.

Our program has been planned for the emotional, physical, social, and intellectual development of the individual child. Your child needs to extend his relationships with others of his own age to learn to be creative, imaginative, cooperative, and to develop social ability, skills, and independence. This is given the utmost attention by our well-trained and dedicated teachers.

Each child will be guided toward finding tools that he can use to cope with the demands of his environment whether they are personal, social, mental, emotional, or physical. Individuality and independence will be encouraged. Each child's large and small muscles will be developed to their greatest potential through structured and unstructured experiences in the environment.

The natural curiosity of the child will be encouraged through free exploration and openness to questioning. The growth of each child's Intellectual and language skills will be encouraged. Within our curriculum, experiences are provided to help each child develop in his own growth pattern.

PROPAGANDIZING AND SOLICITATION

The school should not be used for merchandising. No private selling, soliciting, petitioning, promotional, etc. may be conducted on school property.

Tracts, flyers, posters, etc. not authorized by the administration are not to be brought to school. Programs or special events by outside organizations cannot be promoted. Fundraising programs promoted through home businesses such as Amway, Tupperware, Mary Kay, Avon, etc, will not be considered as a school fundraising program.

Any fundraisers that are conducted by the school are only done so after board approval based on a benefit to the school and non-conflicting interest on the part of a parent, staff member, or student.

RELEASE OF CHILDREN

Please list ALL persons who MAY pick up your child/ren and anyone who MAY NOT pick up your child/ren on the Pickup Form. Your child will only be released to persons listed by you. If there is ever a change in who will pick up your child, it is YOUR responsibility to notify the school office PRIOR to the change. This includes a neighbor, car-pooler, babysitter, or relative that you have not listed previously on the card. If the office is not notified, your child will not be released. This is for your child's protection. The parent/guardian MUST notify the school beforehand. It is the policy of the school to strictly adhere to this rule. No child will be allowed to leave with any other person without the consent of the parent/guardian.

Given the volatility and frequency of child custody problems, it is imperative that this information be updated as needed so we can release your child/ren to authorized persons only. A copy of court orders or documentation must be given to the Steele School in order for us to be able to enforce.

REPORTING SUSPECTED CHILD ABUSE

By law Steele School for Early Learning is required to report any suspected child abuse to the Department of Human Services.

REST TIME

Each child present for full time childcare is required by the State of Colorado to take a rest after the noon meal. Rest time is from 12:30 to 2:30 pm daily for preschool (12:00-2:30 for Toddlers). Sleep is desirable, but not a necessity. Please provide a toddler-size fitted sheet and small blanket for your child's rest mat. Mark it with your child's name in large block letters with an indelible marker. We take care of laundering the sheet and blanket weekly. The child may also bring a "sleeping buddy" to school for naptime. This will be given during naptime only (1 year and older only).

SCHOOL CAMPUS SECURITY

All Steele School for Early Learning staff members are security conscious and policies are in effect to protect your child including our "Closed Campus" policy, May/May Not Pick Up lists, radio communications, and ID log required for all visitors. Staff members are always vigilant to report any suspicious situations to administration immediately and are watching buildings and grounds at all times.

Parents are given a code for the front door. We ask that you not share this, as it can be a security issue. We have a doorbell for people to ring, to get into the building, if they do not have a code.

SCHOOL VISITORS

School visits by parents are encouraged at any time; however, according to the Colorado State Department of Social Services Reg. #7.702.34c visitors who are unknown by Administration or school personnel must first "Log-In" in the Director's Office. Visitors must provide their name, current address, phone number, and state the nature of their visit. Steel School will verify this information with the visitor's current ID (driver's license). A "Visitor's Log" book is provided for this purpose. When a parent has a visitor who is planning to tour the school, please call the school office and set up an appointment. All visitors are expected to show courtesy and good manners during their visit.

SICK CHILD POLICY

Ill children will not be accepted for care. Children with any infectious disease or signs of a communicable disease must remain home. These must be reported to administration. The health of each child will be noted when he/she enters school and during the day. If any symptoms are observed, he/she will be refused admittance or be sent home. Children must be able to eat, drink, and participate in daily activities. Any child who becomes ill while at school will be brought to the office and checked by the administration. Parents will then be called and expected to pick their child up within ½ hour of the call.

Any child who is sent home will be expected to remain at home until they are symptom free for 24 hours without medication.

Symptoms that require exclusion from school include but are not limited to:

--Flu-like symptoms

- Severe and ongoing cough
- Mouth sores
- Rash (dr. note may be required)

SPECIFIC EXCLUSIONS

Steele school follows all the requirements and recommendations put forth by the AAP and state licensing. Steele school reserves the right to have policies in addition to the above. Depending upon circumstances and outbreaks at Steele School reserves the right to extend the exclusion period. Including, but not limited to:

- Pink Eye-Must be on drops for 24 hours before child care returns to care. Please see medication administration for details if drops are needed while at school.
- Lice- Child must have 3 treatments of lice shampoo (over 3 days) and be examined by an admin before they can return to school.
- Diarrhea- If a child has more than 3 diarrhea that cannot be contained in a diaper or underwear the child will be sent home. The child must be diarrhea free for 24 hours before they can return to school.
- Fever- a child must be fever free for 24 hours without the aid of medication for 24 hours before they can return. infants 100F toddlers 100.4F.
- Hand Foot Mouth (Coxsackie Virus) -child must be free of sores inside the mouth, and on the lips; sores must not be weeping/oozing (on any part of the body). If scabs come off during care you will be asked to pick up your child. The child may not return to care for 48 hours from the time of diagnosis. This is in addition to the above. (Dr note required, along with Steele School exclusions.)
- Croup/RSV- Must not be wheezing and have a doctor's note to return. When diagnosed with croup or RSV you must notify the center. The child may not return to care for 48 hours from the time of diagnosis. This is in addition to the above. (Dr note required, along with Steele School exclusions.)
- Vomiting- The child must not be vomiting for 24 hours before they can return to school and also must meet all requirements above.

This is in addition to our Highly Infectious Illness Preparedness Plan. See our Highly Infectious Illness Preparedness Plan below.

SIGN IN AND OUT SHEETS

The parent is required by law to SIGN YOUR CHILD/REN IN AND OUT EACH DAY with your full signature and time. This is a MUST!!! The "Sign-In/Sign-Out" books are located in the childcare office area. We ask that you not take your child from the playground without letting the teacher know and signing your child out. In the event of a fire drill or other evacuation the sign in book is the tool used to account for each child, it is very important that you sign in and out each day.

SMOKE-FREE ENVIRONMENT

No smoking is allowed anywhere on the Steele School for Early Learning campus or grounds by staff members, parents, guardians or visitors.

STUDENT HEALTH RECORDS & IMMUNIZATION FORMS: Students must get a health appraisal completed and signed by their doctor's office. Copies of this form can be found by the sign in book or can be acquired from administration in either paper form or via email. These must be kept updated. Health appraisals are due at 2, 4, 6, 9, 12, 18, and 24 months. After the age of two health appraisals and immunizations are only required annually. An updated immunization record is required at each well child check. This is a requirement for all students and must be kept up to date. If you are on a delayed vaccination plan, this plan must be in writing from your child's doctor then signed and reviewed by the physician, parents, and Steele School. If the plan is not followed this may be terms for dis-enrollment. PLEASE NOTE: Steele School will not accept children that are not fully immunized and will not accept exemptions for medical, personal, or religious.

SUNSCREEN POLICY

Steele School for Early Learning staff will assist with the application of sunscreen to your child with your written request/permission. They will apply it to bare surfaces including the face, tops of ears and bare shoulders, arms, legs, etc., 15-30 minutes before outdoor activities. The childcare staff will sunscreen the children before morning play and before afternoon play. Sunscreen will be reapplied if outside for more than 1 hour. Sunscreen will not be applied to any broken skin or if any skin reaction has been observed. Any skin reaction observed by staff will be reported promptly to the parent/guardian. It is the parent's responsibility to provide sunscreen with a minimum SPF of 30. A Sunscreen Permission Form is available from the Office and is also in the enrollment packet under topical ointment authorization.

TUITION POLICY

Steele School for Early Learning depends on your timely and current tuition payments for its budget. The policy of Steele School is that all tuition is due and payable in ADVANCE of attendance.

All WEEKLY tuition is due MONDAY by 5:30pm of the current week. If a payment is received after Monday at 5:30pm of that week you will be charged an AUTOMATIC \$10.00 LATE CHARGE and an ADDITIONAL \$5.00 for each week that your tuition is past due.

All MONTHLY tuition is due the 1st of each month. If a payment is received after the 5th of the month you will be charged an AUTOMATIC \$20.00 LATE CHARGE and an ADDITIONAL \$5.00 for each week that your tuition is past due, being accrued from the 5th of the month to date. (When the 5th falls on a Saturday or Sunday, tuition payment may be made the following Monday by 5:30pm.)

There is no reduction in rates for illness, holidays, snow days or staff planning days. If this school policy is not respected, your child may be dropped from our school enrollment until your account is made current.

An outstanding balance on an account (tuition or childcare fees) at any point during the year may jeopardize a student's current enrollment at Steele School for Early Learning. Steele School reserves the right to place a student on a waiting list at any point to return, due to an outstanding balance on the account.

There will be a \$35.00 bank charge for all checks that are returned to us for insufficient funds. You will be called when your check is returned to us, and we will charge your account. The school reserves the right to dismiss any family whose checks are consistently returned or require "cash payments only" thereafter.

Potty training rates are independent of which classroom they are in. See Toilet Training section for more details.

TUITION/FAMILY RATES

Steele School for Early Learning will offer a 5% discount for military, service jobs (ie,-; fireman, police, EMT.), and/or families with two or more children enrolled in the school. Discounts may not be combined. Teacher discounts are available. Ask administration for details. Steele School does not accept part time enrollment.

TUITION/PAST DUE ACCOUNTS

A percent per month service charge 1.5 % (annual 18%) may be charged on all accounts 30 day past due. An approximate \$250 service charge will be assessed on all accounts that are turned over to our collection agency. This will happen after all attempts by the school have been ignored. You are to assume that if your account has been turned over to our collection agency, that your child has been withdrawn.

TOILET TRAINING

We will not attempt to toilet train children under the age of 18 months. We will be happy to assist in potty training after the age of 18 months if parents request.

When your toddler turns 2 ½, has a clear understanding of and is consistently involved with the toileting process, is emotionally and socially ready, and there is room in the next classroom he/she may be advanced to the next group. Administration will give you notice when we see your child is ready. To be considered fully potty trained, the child must be accident-free for at least four weeks, this is to include no pull up and dry at naptime. Potty training rates are independent of which classroom they are in.

VIDEO AND TELEVISION VIEWING POLICY

Television and video will not be used in children under 2.5 years old. Children above this age will only use it for the occasional party or fun event (no more than 3 times a year).

WITHDRAWING

We understand that life happens. People move and great opportunities arise. We are always sad to see students and families leave us, however, we understand. If you find yourself in the position that you need to withdraw your student from Steele School for Early learning, a written two weeks notice must be given and what their last day of attendance will be. The two weeks after the date of written notice, are required to be paid for, whether in attendance or not.

If you find yourself in a position of wanting to enroll again. This considered a broken enrollment. Your registration fee and annual fee will be due upon re enrollment.

Steele School Highly Infectious Disease Preparedness Plan Including Pandemic Flu / Emergency Preparedness Plan

Introduction:

Purpose: The purpose of this highly infectious disease preparedness plan is to increase the communication to our staff and students in the event of an outbreak. The plan would serve as a resource guide for planning and responding to a sudden pandemic within our school. Highly infectious illnesses may have a short incubation period, spread easily, and cause severe illness or possible death, and may have no possible existing vaccine or treatment. The purpose of this plan is to achieve the following goals:

- Maximize the protection of lives while minimizing educational and social disruption while reducing morbidity and mortality.
- Enable Steele School for Early Learning to continue to operate and provide services as normally and effectively as possible in the event of a highly infectious disease outbreak with minimal academic and economic losses. Steele School for Early Learning's response will be directed by Jefferson County Public Health (JCPH) Department's and State Licensing's direction and guidance. This plan coordinates federal, state, and local agencies.
- Continue the essential core operations of Steele School for Early Learning in the event of increased staff/student absences due to a highly infectious outbreak.
- Establish and maintain a coordinated command system with the JCPH, State Licensing, CDC, our nurse consultant, and Steele School for Early Learning.
- Develop a communications plan to ensure that students, parents, and staff receive timely and accurate information regarding disease prevention strategies and infection control strategies.

Steele School for Early Learning recognizes that our schools are a critical community institution for many people, staff and children. The threat of a highly infectious outbreak in our schools could be detrimental to the community. By following this highly infectious disease preparedness plan, we are dedicated to reducing the miscommunications that may encompass the chaotic nature of an outbreak of any highly infectious illness. This plan outlines Steele School for Early Learning's strategy in preparing for, responding to, and recovering from a highly infectious disease outbreak such as Pandemic Flu in a collective, community approach. Steele School for Early Learning will coordinate with JCPH for any antibiotics or other treatments for staff, families, and other Jeffco community members; coordinate with other close districts for safety measures related to the outbreak; Prepare and provide for mental health/crisis service needs of staff, students and families.

Scope:

The scope of this preparedness plan covers the most prevalent highly infectious illnesses such as Pandemic Flu, other airborne respiratory illnesses – COVID-19 (coronavirus), MERS and SARS, Ebola, airborne viruses such as Anthrax, and all other unknown diseases.

Pandemic Flu will be the most concentrated. Pandemic Flu – Influenza – Influenza (flu) viruses can cause a severe illness, even death. Younger and older populations as well as populations with certain health conditions (asthma, COPD, heart disease, neurological disorders, blood disorders, endocrine disorders, kidney disorders, and weakened immune systems) are at a high risk of serious flu complications. Flu viruses are grouped into three types, designated A, B, and C. Type A – can affect both humans and animals, and are associated with more severe illness. Usually the cause of global pandemics. Type B – infect only humans and cause seasonal outbreaks and less severe disease than A in the United States (US). Does not cause pandemics. Type C – Very common, usually cause mild respiratory symptoms. The average incubation period (time between infection and onset of symptoms) for seasonal flu is TWO days. Flu symptoms are only passed human to human by respiratory secretions. People infected with the flu viruses may shed the virus and transmit the infection up to one day before the onset of symptoms. Viral shedding and the risk of transmission will be greatest during the first three-four days after the onset of symptoms. An influenza pandemic is a global outbreak of a NEW INFLUENZA VIRUS that is very different from current and circulating influenza A viruses. Pandemics happen when new influenza A viruses emerge which are able to infect people easily and move quickly person to person. Influenza viruses come from different animals including birds and pigs from the past, most recent pandemics. In a pandemic influenza, the influenza A virus in these animals may shift to what’s called an “antigenic shift.” The antigenic shift represents an abrupt, major change in an influenza A virus. This can result in a direct non-human human transmission. Once this occurs in one person and is able to move to another person, this is now defined as a pandemic. Pandemics happen quickly and move fast from country to country.

Seasonal Flu:	Pandemic Flu:
Happens annually and peaks between December and February	Rarely happens: 3 times in 20 th century
Usually there is some immunity from previous exposures and influenza vaccines	Most people have little or no immunity because they have no previous exposure to the virus or similar viruses
Certain people are at risk for flu complications – elderly, infants, people with chronic health conditions	Even healthy people are at risk for serious complications
Health care providers can meet the needs of patients easily	Health care providers and hospitals are overwhelmed and it is very difficult to meet the needs of the exposed public
Vaccines are updated annually and one dose is sufficient	Although the US govt maintains a stockpile of pandemic vaccines, the overwhelming need of vaccines may not be available, and may require 2 doses
Usually cause minor impact on schools and the public. Sick people should stay home	May cause major impact on the general public. May cause travel restrictions, school and business closings
Antiviral drugs are readily available and help within the first 48 hours of presenting symptoms	Antiviral drugs will still be prescribed, but will be less readily available and more difficult to come by. Symptoms will also be more severe and antivirals may not be as helpful

Differences between seasonal influenza and pandemic influenza:
 Treatments for pandemic flu include antiviral drugs and non-pharmaceutical interventions (NPIs). These actions do not include medications or vaccinations. NPIs will be the only early intervention tools that will most likely mitigate the quick transmission from person to person. See more about mitigation strategies in the later section, Prepare – Prevent - Protect.

COVID-19 (Novel Coronavirus) -Symptoms of Coronavirus- Updated November, 2020 (guidance from John Hopkins University)

COVID-19 is the disease caused by the new coronavirus that emerged in China in December 2019. COVID-19 can be severe, and some cases have caused death.

The new coronavirus can be spread from person to person. It is diagnosed with a laboratory test. There is no coronavirus vaccine yet. Prevention involves frequent hand-washing, coughing into the bend of your elbow, staying home when you are sick and wearing a cloth face covering if you can't practice physical distancing.

How does the new coronavirus spread?

As of now, researchers know that the new coronavirus is spread through droplets released into the air when an infected person coughs or sneezes. The droplets generally do not travel more than a few feet, and they fall to the ground (or onto surfaces) in a few seconds — this is why physical distancing is effective in preventing the spread.

What is the incubation period for COVID-19?

It appears that symptoms are showing up in people within 14 days of exposure to the virus.

COVID-19 symptoms include:

Cough

Fever or chills

Shortness of breath or difficulty breathing

Muscle or body aches

Sore throat

New loss of taste or smell

Diarrhea

Headache

New fatigue

Nausea or vomiting

Congestion or runny nose

In rare cases, COVID-19 can lead to severe respiratory problems, kidney failure or death.

If you have a fever or any kind of respiratory difficulty such as coughing or shortness of breath, call your doctor or a health care provider and explain your symptoms over the phone before going to the doctor's office, urgent care facility or emergency room. Here are suggestions if you feel sick and are concerned you might have COVID-19.

If you have a medical emergency such as severe shortness of breath, call 911 and let them know about your symptoms.

What Is Coronavirus?

How is COVID-19 diagnosed?

Diagnosis may be difficult with only a physical exam because mild cases of COVID-19 may appear similar to the flu or a bad cold. A laboratory test can confirm the diagnosis. Learn more about COVID-19 testing.

How is COVID-19 treated?

As of now, there is not a specific treatment for the virus. People who become sick from COVID-19 should be treated with supportive measures: those that relieve symptoms. For severe cases, there may be additional options for treatment, including research drugs and therapeutics.

Does COVID-19 cause death?

As of November 11, 2020, 1,274,526 deaths have been attributed to COVID-19. However, 33,623,602 people have recovered from the illness. This information comes from the Coronavirus COVID-19 Global Cases map developed by the Johns Hopkins Center for Systems Science and Engineering.

How do you protect yourself from this coronavirus?

It's crucial to practice good hygiene, wear a mask, respiratory etiquette and physical distancing. Read more about ways to protect yourself.

How can the staff and children keep themselves safe?

All staff and children above 2.5 years old will be required to wear a mask. Children will when they are inside and cannot social distance. Masks will not be worn outside, at mealtime, or during nap.

Continue to stay up to date and learn more by visiting :

<https://www.cdc.gov/coronavirus/2019-ncov/index.html>

MERS & SARS – Middle East Respiratory Syndrome and Severe Acute Respiratory Syndrome. MERS – also known as the “camel flu.” A fairly new respiratory virus for humans. Symptoms include fever, cough, diarrhea, and shortness of breath. February 26, 2020 Page 5 of 12 Some experience symptoms involving the gastrointestinal tract as well causing nausea, vomiting, and diarrhea. Spread through respiratory droplets is the believed transmission, however this is still being studied. Incubation period is approximately 5-7 days. Mortality hits one-third of diagnosed cases. Spread is uncommon outside of hospitals, thus the risk to the global community is fairly low. No diagnosed cases in the US since 2014. No vaccine or treatment. SARS – severe respiratory illness that started in southern China. No cases have been diagnosed since 2004. Initial symptoms are flu-like including muscle pain, high fever, sore throat, cough, severe muscle aches, and possible diarrhea. These symptoms may lead to shortness of breath and/or pneumonia. Incubation period is 4-6 days, although it has been known to incubate for one day. Transmission is through respiratory droplets. Although there is some belief that SARS may be spread through airborne transmission – meaning spread by tiny pathogens in the air that are inhaled.

Anthrax – A serious infectious disease can cause death. Anthrax gets into the body through the skin, lungs, or gastrointestinal tract. All types of Anthrax are bacterial and can spread throughout the body quickly if not treated with antibiotics. Cutaneous – most common and least dangerous – through the skin. Possible exposure comes from workers who handle contaminated animal products and get spores in a cut or scrape on

their skin. Infection develops in 1-7 days after exposure. Inhalation – Most deadly form of Anthrax. Occurs when a person inhales spores that are aerosolized during the industrial processing of contaminated materials, such as wool, hides, or hair. Infection develops within a week after exposure, but it can take up to 2 months.

Gastrointestinal – Rarely reported in the US. People who eat raw or undercooked meat from infected animals could get sick with this. Infection develops from 1-7 days after exposure. Injection – This Anthrax has never been reported in the US. Seen in northern Europe in people injecting heroin. People at risk are people who handle animal products, veterinarians, livestock producers, travelers, laboratory professionals, mail handlers, military personnel, and response workers. The Anthrax vaccine is currently provided only to people who are at an increased risk of coming in contact with anthrax spores, such as members of the US military, certain laboratory workers, and some people who handle animals or animal products. The vaccine is not licensed for use in children under age 18, adults over age 65, or pregnant and nursing women. We do not know when Anthrax will occur, however, federal agencies have worked for years with health departments across the country to plan and prepare for an anthrax attack. Anthrax can be used as weapon because spores are easily found in nature, can be produced easily, and can last a very long time in the environment. These spores are released quietly and without anyone knowing. The spores cannot be seen, smelled, or tasted.

Ebola – a rare viral hemorrhagic fever in humans and non-human primates. The virus starts between 2 days and 3 weeks after contracting the virus. Symptoms show up as a fever, sore throat, muscular pain, and headaches. Vomiting, diarrhea, and a rash may follow along with decreased function of the liver and kidneys. An infected person may bleed both internally and externally and has a very high risk of death, killing between 25-90% of those infected. Death often occurs from low blood pressure due to loss of blood. The virus spreads through direct contact with body fluids, such as blood, urine, feces, semen, breast milk, sweat, and vomit. An Ebola vaccine is currently being studied in Africa with promising factors, nothing current in the US thus far. No specific treatment is singled out for Ebola, however, supporting treatments will have to take place such as intravenous fluids, pain management, anti-nausea, and fever control. If infected, recovery depends on the person's immune response. Ebola survivors may carry the illness in their blood for up to 10 years post recovery. Personal Protective Equipment (PPE) would be issued for all public health planners in working with the potential of the Ebola virus. February 26, 2020 Page 6 of 12

Authorities/Roles & Responsibilities:

WHO, US Dept of HHS, CDC, CDPHE, and Steele School for Early Learning are the Authorities. During an outbreak of a highly infectious illness, the US Government – US Department of Health and Human Services (HHS) along with the Centers of Disease Control (CDC) is the national leader for overall communication and coordination efforts. If it is universal, they work correspondingly with the World Health Organization (WHO).

US Department of Health and Human Services along with the CDC's role is:

- Identify, appoint, and lead the highly infectious disease response; enact or modify legislation and policies required to sustain and optimize pandemic preparedness, capacity development, and response efforts across all sectors.
- Lead national and domestic efforts in surveillance and detection of outbreaks.
- Prioritize and guide the allocation and targeting of resources to achieve the goals as outlined in a country's response.

- Provide additional resources for national pandemic preparedness, capacity development, and response measures.
- Support rapid containment of outbreaks, provide guidance to state level authorities on the use and timing of community infection control measures.
- Support biomedical research and development of new vaccines and medical countermeasures.
- Consider providing resources and technical assistance to countries experiencing outbreaks of the highly infectious illness.

The Colorado Department of Public Health and Environment (CDPHE) takes lead from the CDC. Jefferson County Public Health Department (JCPH) takes lead from the CDPHE. Both together, in collaboration have natural leadership and advocacy in highly infectious illness preparedness and response efforts. In cooperation with these public health sectors, Steele School for Early Learning cooperates in efforts to raise awareness and actions that are necessary in response to the severity of the phase of reported illness. The risks and potential health consequences are taken into consideration by CDPHE and JCPH and assist Steele School for Early Learning in the following:

- Provide reliable information on the risk, severity, and progression of the outbreak and the effectiveness of interventions used during the outbreak.
- Activate the CDPHE Department Operations Center (DOC), and notify the Governor, the Governor's Expert Emergency Epidemic Response Committee (GEERC), and the Colorado Division of Homeland Security and Emergency Management. CDPHE will collaborate with response agencies in the State Emergency Operations Center to coordinate response activities.
- Prioritize and continue the provision of health-care during a highly infectious outbreak.
- Maintain situational awareness by monitoring the highly infectious illness surveillance data and assessing the public health/medical needs of Colorado.
- Enact steps to reduce the spread of the infection in the community and in health-care facilities.
- Provide guidance, resources, and technical assistance to local health departments and aid in the need/use of vaccines, anti-virals, and antibiotics. JCPH will then coordinate with Steele School for Early Learning for the distribution of these medications/supplies.
- Coordinate with public and private healthcare systems to ensure a cohesive healthcare response statewide to handle inpatient and outpatient care.
- Protect and support health-care workers during the infectious outbreak.
- Provide PPE if needed along with other protective supplies to protect healthcare workers from transmission and infection control procedures.
- Notify the local health departments if social distancing and community mitigation is needed, such as closing schools, travel restrictions, cancellation of local, public events, isolation and/or quarantine may be required to slow the spread of the illness.

Closures:

Steele School for Early Learning will communicate to employees, students and families, and community members via email and our website. We will maintain school and stay in session until notified by authorities for the need to close. Non-pharmaceutical interventions, travel restrictions, cancellation of public events, isolation and/or quarantine may be required to slow the spread of an outbreak. Steele School for Early Learning will work

closely with the CDC, JCPH, our RN consultant to monitor the need for closure. The closure time can vary depending upon the recommendations and locations of the outbreaks. Childcare is considered essential personnel by the government; due to this we may follow different closure schedules or choices than public schools. In the event of a closure, there will be no break in tuition. It will be paid just as a snow day or holiday would. Steele School reserves the right to change this as we deem necessary. In the event of an extended closure, as determined by Steele School, tuition discounts may be implemented. Using our decision tree when we have strong recommendations, suggestions, or mandates to close from any governing agencies, including, but not limited to the President of the United States and/ or Colorado Governor and/or the CDPHE and/or JCPH we will implement these procedures per the Steele School administration's discretion.

Closures include Force Majeure events defined as; an event or effect that cannot be reasonably anticipated or controlled. Force Majeure events include, but not limited to: Natural disasters and/or epidemics and/or pandemics. If these events cause damage to the building and/or premises to the extent that conditions are unusable and /or deemed not safe. Steele School will close for an undetermined amount of time. All tuition in arrears will still be due.

Steele School for Early Learning's Response to an infectious illness is as follows :Our RN consultant will continue to educate school communities on prevention of illness: vaccinations, proper hand washing techniques, community mitigation, and social mitigation for prevention of transmission. Prepare the school communities to minimize health risks. Train all staff and students on these measures. Our RN consultant and school administration will develop plans with families in the event their child must be sent home due to illness or if schools are closed. Steele School for Early reserves the right to extend and/or add to these exclusions as we need in conjunction with advice from our health department and RN consultant.

If a child shows any outbreak symptoms as defined by the CDC. Steele School policy will be excluded per the CDC and CDPHE guidelines.

PICK UP/ DROP OFF DURING OUTBREAK/PANDEMIC

In the event of an outbreak or pandemic these will be the procedures for drop off and pick up:

Drop-off

When arriving at Steele School, please pull to the front of the entrance doors. A staff member will be outside to greet you. We will sign your children in and out. We will take your temperature and your child's temperature, take them into the building, and walk them to class. You will have to unbuckle your child from their car seat, if applicable.

Infants- since we cannot take infants out of the car seat infant parents will bring their child and belongings in and hand them to the teachers over the half door. We will take your temperature and your child's temperature before they enter the classroom. Infant 1 outside door will not be used. Please use our main entrance.

This policy was put in place by Steele School, with recommendations from the Health Department and CDC.

Your child will not be admitted for care if any of the following criteria are applicable:

1. Parent or child have a temperature of 100.4°F or higher
2. Excessive / Wet cough
3. Any flu-like symptoms

Pick Up

Parents will pull to the front entrance of the building. A staff will greet them, radio to their child's classroom, and walk them to the car. If you would like to call before arriving (10 min), please do so. This will help expedite the pick up process. Call us at 303-431-5653 or text 303- 809-0158 with the following information;

Parent name

Child name

Estimated time of arrival

Assumptions:

Colorado Governor may declare a State of Emergency, resulting from a public health emergency – highly infectious illness – i.e. pandemic flu. Response to this outbreak – pandemic will require swift and coordinated action by all levels of government. CDPHE will take the role of Lead State Agency for emergency support and will coordinate with Colorado Emergency Management, within the Division of Homeland Security and Emergency Management and other state and local agencies, as part of a unified command structure. Effective prevention and therapeutic measures, including vaccine and antiviral medications, could be delayed, in short supply, or not available. Substantial public education regarding the need to target priority groups for vaccination and antiviral/antibiotic medication and the allocation of limited supplies, is crucial in averting public panic. Non-pharmaceutical interventions, travel restrictions, cancellation of public events, isolation and/or quarantine may be required to slow the spread of an outbreak. Secondary bacterial infections, following the outbreak, may result in shortages in antibiotic supplies. JCPH will work with healthcare providers to coordinate the distribution of vaccines, antivirals, and other medications and/or medical supplies. Jeffco district RNs may be used for this. There may be a need for alternate care sites as a temporary health facility. Healthcare workers, firefighters, and police officers may be at higher risk of exposure and illness than the general population, further straining the outbreak response. Widespread illness could increase the likelihood of sudden and potentially significant shortages of personnel in other sectors that provide critical public safety and necessary services. It may be necessary to expand mortuary service capacity including Disaster Mortuary Operational Response Teams (DMORT) through CDPHE. If Pandemic Influenza, it will occur in waves – up to 2 months with little or no flu activity and last as long as 18 months where there is risk associated with the public. Pandemic influenza is known to spread rapidly from one person to the next through coughing or sneezing. Some people may become infected by touching something with the flu virus on it and touching their nose, mouth, or eyes. Influenza may shed the virus for one to two days before becoming symptomatic.

Prepare – Prevent – Protect:

Preparedness refers to those actions and measures taken before an event in order to better handle the emergency when it arises. CDC plays a prevalent role in making sure states and local health departments are prepared for public health emergencies. CDPHE and JCPH will prepare Steele School for Early Learning before, during, and after exposure to a highly infectious illness. Public health officials recommend prior to and in the early phases of a pandemic or outbreak, to practice every day good health habits and to non-pharmaceutical interventions (NPIs) to prevent and protect the human population from the spread of a highly infectious illness. Everyday good health habits include the following:

- Avoid close contact with people who are sick. When you are sick, stay away from others to prevent passing on your illness to others.
 - Stay home when you are sick so you prevent passing your illness on to others.
 - Cover your mouth and nose when sneezing or coughing with a tissue and then throw away the tissue.
 - Wash your hands after coughing or sneezing and often throughout the day.
 - Washing the germs is always best and the preferred method. If soap and water is not available, hand sanitizer will kill the viruses, but not wash them away. (Steele School for Early Learning's hand washing protocol is here.
 - HANDWASHING-Handwashing is the single most effective practice that prevents the spread of germs in the child care setting. When should hands be washed?
 - Children:
 - Upon arrival to the center
 - Before and after eating
 - After using the toilet/diapering
 - Before using water tables
 - After playing on the playground
 - After handling pets
 - After coughing or contact with runny noses
 - Whenever hands are visibly dirty
 - Before going home
 - Providers
 - Upon arrival to work
 - Before handling food or feeding children
 - After using toilet/diaper changing
 - After coughing, contact with runny noses, vomit, etc
 - After handling pets or pet cages
 - Whenever hands are visibly dirty
 - Before and after administering first aid
 - After cleaning up
 - After removing gloves
 - Before giving medication
 - Before going home
 - How to wash hands
 - Use liquid soap
 - Wash well under running water for at least 10-15 seconds.
 - Be sure to wash areas between fingers, around nail beds, under fingernails and back of hands
 - Use hand lotion Hand sanitizers may be used for staff and children 3 years of age and older, at times and in areas where handwashing facilities are not available
- Infants and Toddlers
 - Use soap and water at a sink if you can.
 - If a baby is too heavy to hold for handwashing at the sink then:

- Wipe the child's hands with a damp paper towel moistened with a drop of liquid soap.
 - Wipe the child's hands with a paper towel wet with clear water
 - Dry the child's hands with a paper towel
 - **Do not use hand sanitizers for young children under 3 years of age**
- Avoid touching your face, eyes, nose, or mouth. Germs are often spread touching these body parts.

Practice other good health strategies:

- clean and disinfect surfaces in your home, especially when someone is ill.
- Get plenty of sleep
- manage your stress
- be physically active

Other than everyday good health habits, other NPIs are thoughtful mitigation strategies to protect the community and are consistent of:

- Social distancing – create ways to provide distance between people in close contact areas including work and school.
- Closures – possible closures of non-urgent/mandated events – not necessary to hold extra community events during an outbreak or pandemic. Be prepared and informed, take an active participation in the event of an outbreak or pandemic.
- Communicate with other employees, students, and community members by using educational materials to inform on updates of the outbreak or pandemic, good hygiene methods including hand washing protocol, hang posters, send email reminders, and face to face training/presentations.
- Continue communicating surveillance and monitoring the outbreak or pandemic.
- Maintain a clean environment.
- Educate the community on when to stay home when you are sick.
- Limit your travel to parts of the country/ world that have a high number of reported cases. Adhere to travel bans.

Other preparedness measures for Steele School for Early Learning include: Our administration team composed of the Owner, Director, and our Assistant Director are crucial; this leadership team delegates necessary tasks and duties to all employees according to JCPH and CDPHE's guidance and direction. Important that together, this team communicates the same message to all employees, students, parents, and community members. Teachers prepare lesson plans ahead of time in case they are out due to illness and/or students are out due to illness. Steele School for Early Learning has cross trained staff to ensure that if staff is gone, other employees are able to fulfill those roles.

In the case that one case is confirmed, Steele School for Early Learning will transition to the Response phase.

Respond:

During an outbreak/pandemic, Steele School for Early Learning focuses on the school district's response to and management of a confirmed case.

Identify: The confirmed case from JCPH begins practicing the mitigation of NPIs including social distancing noted above. Identification of a confirmed case starts the process of an outbreak/pandemic emergent situation. Guidance from CDPHE JCPH Steele School for Early Learning. During this time, Steele School for Early Learning will take a more active awareness to the everyday good health habits and NPIs as this is our biggest defense to a highly infectious illness preparedness plan. It is our number one goal to keep our students, staff, parents, and all other community members as safe and healthy as possible, therefore, we will communicate and educate these stakeholders on an often, routine basis to keep the messages flowing about where we stand as a community in this highly infectious illness process.

Activate: As this process of a highly infectious illness plan comes to fruition, we must look at the Incident Commander chart (also in Appendix) for Steele School for Early Learning s and follow this for the proper emergency response. Director of Department of Health Services will get direct communication and notification of a confirmed case of a highly infectious illness student or staff and then will work directly with the district Incident Commander and the Department of School Safety to activate proper operations. Quarantine and Isolation – JCPH will utilize the Jefferson County PHEOP Community Containment Annex to address community mitigation measures specific to community containment interventions, such as isolation and quarantine during an outbreak/pandemic. Community containment interventions are implemented to help prevent or reduce the spread of an infectious agent(s) within the community. If voluntary home quarantine measures are suggested for exposed household members, Steele School for Early Learning will communicate with staff, students, parents, and community members as a need to help mitigate the highly infectious illness. Depending on the severity of the event, Steele School for Early Learning will take direction from government officials including law enforcement, CDPHE, and JCPH for next steps.

Conduct: Conducting a full emergency operation at Steele School for Early Learning will take the guidance and expertise of the Department of School Safety and the Department of Health Services. This may involve requests of Supervisors and district RNs. The Director of Health Services will activate the Nurse Response Team (NRT) or needed capacity. Steele School for Early Learning will initiate data collection of absenteeism and provide JCPH with data they will be needing for report to CDPHE. Steele School for Early Learning s will need the Research and Assessment team to provide support in this area and direction for operation in collecting and analyzing all data. During any highly infectious illness outbreak/pandemic, Steele School for Early Learning will maintain surveillance data and contribute to JCPH and CDPHE in a proactive, positive manner to increase the health and safety of our community.

Recover: Community Assessment post a highly infectious illness outbreak/pandemic requires completed surveillance data and feedback of operations. Any damage done to the community from this highly infectious illness outbreak/pandemic will be defined and analyzed for proper future planning. It is crucial Steele School for Early Learning enforces resources and guidance for all staff, students, parents, and community members to focus on “getting back on track.” Stress the importance of returning to normal practice and procedures for the health and safety of everyone. Return as quickly as possible to normally scheduled school days including all scheduled events. Steele School for Early Learning will assess the need for additional mental health support resources and provide as much as possible to staff, students, parents, and the community. The Department of Student Success will help identify mental health resources for the community. Steele School for Early Learning’s Community and Family Connection Department (CTC) will also assist in supporting Jeffco families with any resources that may be needed during or after a highly infectious illness outbreak/pandemic. Steele School for Early Learning will communicate through the Communications Department when it is safe to return to school and what precautions, if any, will need to occur. All school grounds and property will be cleaned and equipment

may need to be sterilized. The Facilities Department will help support this practice. Steele School for Early Learning s will continue to monitor the illness and provide data as needed to continue the transparency of communication to the community. Steele School for Early Learning will establish a “return to learning” program to get students who have missed several days of instruction back on track. Some assignments may need to be eliminated depending on students’ performance on content mastery. Debriefing between CDPHE, JCPH, and Steele School for Early Learning will occur many times post event to ensure adequate data collection was successful and to begin proper preparation for the next highly infectious disease outbreak/pandemic. Success and failures will be discussed in transparency to determine the proper planning in the future.

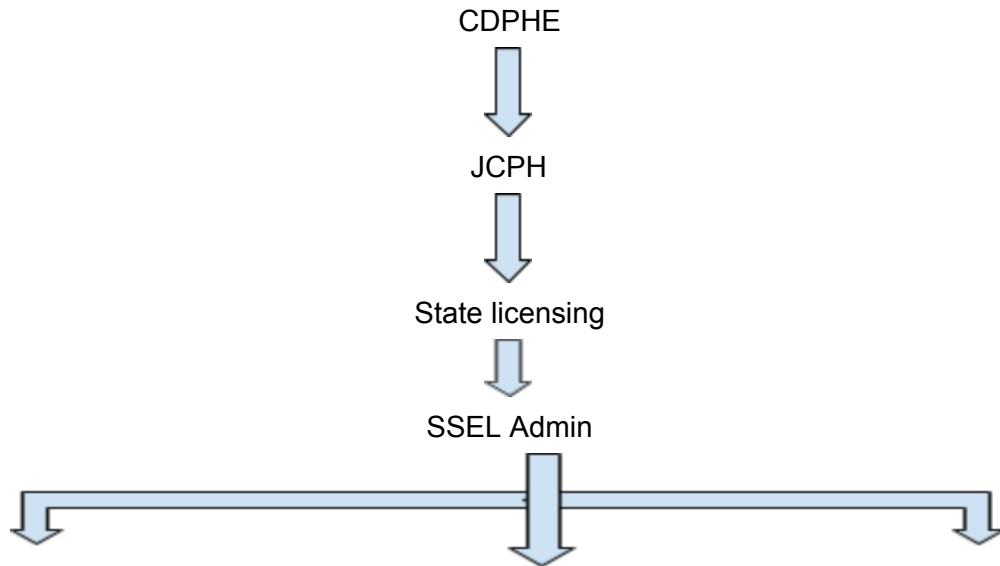

PUBLIC INFORMATION OFFICER (Communications Services)	OPERATIONS & CURRICULUM & INSTRUCTION STUDENT DATA Health records	FINANCE ADMINISTRATION Tuition Policy Rules and Regulations INTERIM & FINAL CLOSURE DECISIONS
Sarah Highland	Krista Neues	Amy Higginbottom
Assistant Director	Director	Owner